



# GENTEX CORPORATION

## Photoelectric Smoke Alarm 120VAC/9VDC Single/Multiple Station Smoke Alarm

## S 1 2 0 9 S E R I E S

### Applications

The S1209 (120VAC/9VDC) Series photoelectric smoke alarms are for use as an evacuation device in all dwelling units, including but not limited to homes, apartments, hospitals, hotels and motels. The S1209 Series is listed in compliance with ANSI/UL 217 for installation per NFPA 72 and the international codes (IBC/IFC/IRC).

Available in two models, the S1209 Series is engineered to virtually eliminate nuisance alarms and deliver outstanding performance wherever reliable smoke detection is required.

The S1209 Series is provided with a 9VDC alkaline battery for emergency power back-up in the event building power is lost. The battery impedance is verified and the alarm provides a low or missing battery warning. The battery drawer provides easy replacement without removing the unit from the wall or ceiling.

The Gentex S1209 Series is provided with a push button self test and functionality test feature. The push button self test verifies power operation and tests battery levels. The push and hold button functionality test analyzes the photoelectric sensing chamber for proper operation of smoke alarm. The self and functionality tests are in compliance with NFPA 72 and ANSI/UL Standards.

**Features of the smoke alarm series include DUALINK® tandem capabilities with all Gentex tandem interconnect capable smoke alarms, CO alarms and combination smoke/CO alarm products.** Options include Form A/Form C dry contacts for remote annunciation and connection to a protected premises alarm system to provide a supervisory/trouble signal. The S1209 Series provides Temporal 3 evacuation tone for the smoke alarm units



### Product Listings

#### SIGNALING



LISTED



- ANSI/UL 217 Listed
- CSFM - Pending

### Product Compliance



- NFPA 72
- IBC/IFC/IRC
- City & State Ordinances/Laws/Regulations
- Quality Management System is certified to: ISO 9001:2008

### Standard Product Features

- S1209 is 120VAC with 9VDC battery back-up
- Photoelectric smoke sensing technology
- Horn frequency 3100 Hz (nominal)
- Temporal 3 evacuation audible signal
- Optional Auxiliary Form A/Form C relay contacts (F model)
- Relay contacts operate when on battery back-up
- Nominal 2.5% sensitivity
- Push button self test feature, verifies power sources/operation
- Push and hold button functional test feature, analyzes sensing chamber
- Quick-disconnect wiring harness
- DUALINK® - tandem with all Gentex tandem capable alarms, including CO and smoke/CO
- Red LED pulses every 30 seconds, green LED for AC power on
- Solid State Red LED to indicate smoke presence
- Mounting hardware adapts to standard junction boxes, including but not limited to 4x4x2-1/8 octagon.
- Dust cover to prevent particle contamination during installation
- Low or missing battery indicator
- 12 month warranty from date of manufacture or 18 months from date of purchase

### Electrical Specifications

Operating Voltage	.....120VAC, 60Hz
Operating Current	.....045 amps
Operating Current (Relay Options)	.....070 amps
Operating Ambient Temp Range	.....40°F-100°F .....(4.4°C-38°C)
Alarm Horn Rating	.....meets or exceeds ......85dBA at 10ft (3.048 m)
Auxiliary Relay	.....1 Form A & 1 Form C (0.6 amp)
Size	.....Diameter: 5.75 in. (14.605 cm) OA .....(6.25 in. (16.51 cm) at Ceiling) .....Depth: 1.8 in (4.572 cm)
Secondary Power Source	.....9 VDC alkaline battery

Model Number	Part Number	Voltage	9VDC Battery Back-Up	Form A/ Form C Relay
S1209	917-0059-002	120VAC	●	
S1209F	917-0057-002	120VAC	●	●

# S1209 SERIES

## S1209 Series Wiring Diagrams

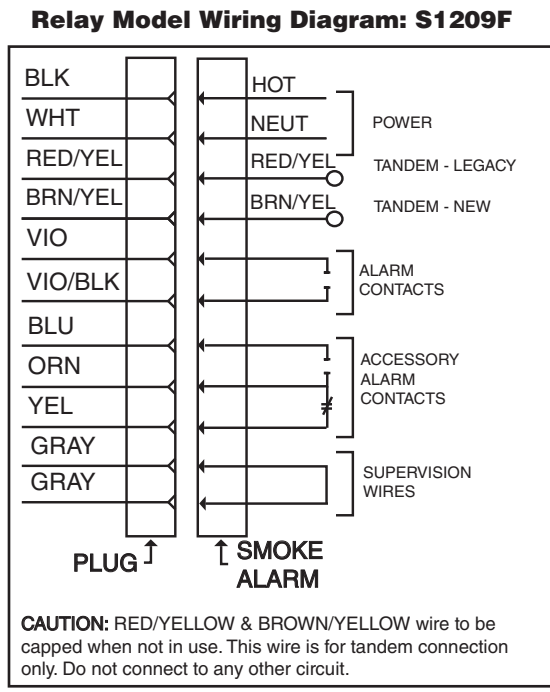
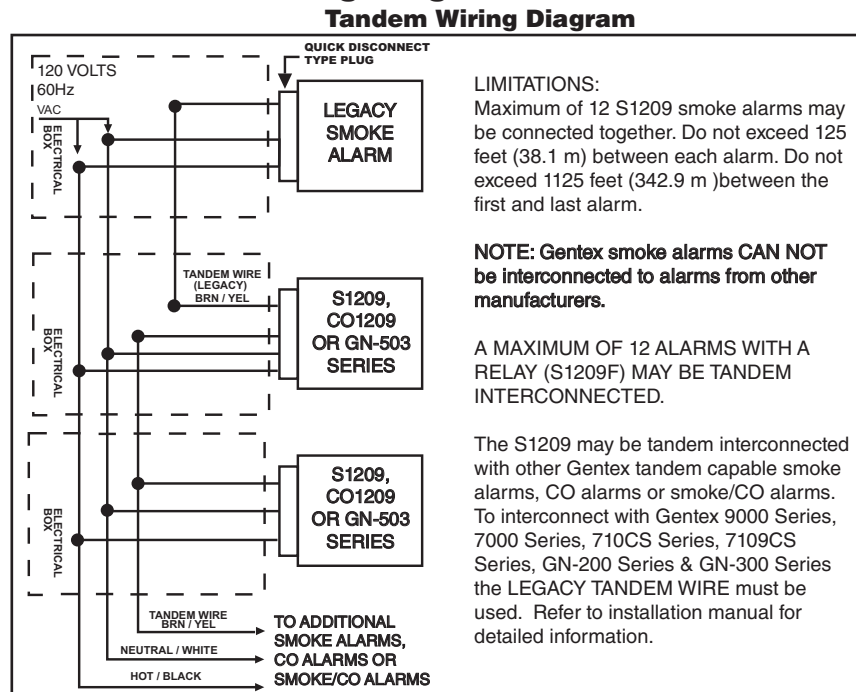

**NOTES:**

- Utilizing DUALINK®, if S1209 alarm annunciates, all smoke alarms, CO alarms or combination smoke/CO alarms tandem interconnected will sound smoke alarm warning.
- Utilizing DUALINK®, if S1209 is tandem interconnected with CO alarms or combination smoke/CO alarms and CO devices go into alarm, CO alarms and smoke alarm will sound CO warning.
- When both smoke and CO conditions are present, smoke condition will have priority and alarm will sound smoke annunciation.

**Refer to NFPA 72, 2010 Chapter 29, Section 8.2.2(5) for further product compliance information.**

**Architect & Engineering Specifications**

The photoelectric smoke alarm shall be a Gentex Model S1209/S1209F or approved equal which shall provide at least the following features and functions:

1. Nominal smoke sensitivity shall be 2.5%.
2. The smoke alarm portion of device shall utilize an infrared LED sensing circuit which pulses in 4 to 5 second intervals when subjected to smoke. After 2 consecutive pulses in smoke, the alarm will activate.
3. The S1209 Series alarm shall have a Duracell MN 1604 9VDC alkaline battery as a back-up in the event building power is lost.
4. The 9VDC battery impedance shall be verified by the circuit of the smoke alarm.
5. The alarm shall provide an indicator when the battery is low in power, high impedance or is missing.
6. A solid state piezo alarm meets or exceeds the rating of 85dBA at 10ft.
7. A visual LED monitor (condition indicator) will slow pulse in normal operation and rapid pulse in alarm (red color)
8. An easily accessible test button shall be provided. Push down on button for 5 seconds causing smoke alarm to activate. If device does not go into alarm, the device is not working properly.
9. The device shall have tandem interconnect capability of up to 12 smoke alarms.
10. The alarm shall have the capability to tandem interconnect with all Gentex tandem capable smoke alarms, CO alarms or combination smoke/CO alarms, including 7000/7003 Series, 9000/9003 Series, 710CS/713CS Series, 7109CS/7139CS Series, GN-200/GN-300 Series, CO1209 Series and GN-503 Series
11. The manufacturer shall provide models with the optional feature of auxiliary Form A/Form C relay contacts for initiating remote functions and annunciation
12. Unit must be ANSI/UL 217 listed for both wall and ceiling mounting.
13. Unit shall be listed by Underwriters Laboratories and California State Fire Marshal (CSFM).

All equipment shall be completely factory assembled, wired and tested, and the contractor shall be prepared to submit a certified letter testifying to this condition. Alarms which do not meet all of the requirements of this specification will not be considered.

For complete product specifications, refer to product installation manual.

24 units per carton  
24 pounds per carton



Fire Protection Products Group • www.gentex.com  
10985 Chicago Drive • Zeeland, Michigan 49464  
616.392.7195 • 1.800.436.8391 • 616.392.4219 Fax

Gentex Corporation reserves the right to make changes to the product data sheet at their discretion.

**Important Notice:**

These materials have been prepared by Gentex Corporation ("Gentex") for informational purposes only, are necessarily summary, and are not purported to serve as legal advice and should not be used as such. Gentex makes no representations and warranties, express or implied, that these materials are complete and accurate, up-to-date, or in compliance with all relevant local, state and federal laws, regulations and rules. The materials do not address all legal considerations as there is inevitable uncertainty regarding interpretation of laws, regulations and rules and the application of such laws, regulations and rules to particular fact patterns. Each person's activities can differently affect the obligations that exist under applicable laws, regulations or rules. Therefore, these materials should be used only for informational purposes and should not be used as a substitute for seeking professional legal advice. Gentex will not be responsible for any action or failure to act in reliance upon the information contained in this material.

551-0001-01