



US Patent No. 6,945,509

RBVS Stock No. 1000040 (w/o Cover Tamper)
RBVS-T Stock No. 1000035 (w/Cover Tamper)

UL and cUL Listed, FM, CSFM Approved

Dimensions: (including mounting clamps)

Large Clamps: 6" L x 5" W x 5.2" H
15,2 cm L x 12,7 cm W x 13,2 cm H

Small Clamps: 6" L x 4" W x 5.2" H
15,2 cm L x 10,2 cm W x 13,2 cm H

Weight:

With Large Clamps: 13.6 oz. (386,9 g.)
With Small Clamps: 11.0 oz. (311,2 g.)

Enclosure:

Non-Corrosive Composite Material

Environmental Limitations:

- NEMA 4 rated enclosure when proper electrical fittings are used. (IP67)
- Temperature range: -40°F to 150°F (-40°C to 65°C)
- Not for use in hazardous locations

Housing Cover Tamper: Activated by housing cover removal
(Stock No. 1000035 only)

Contact Ratings:

SPDT Contacts: 10A at 125/250 VAC
2A at 30 VDC
SPDT Cover Tamper: 3A at 250 VAC

General

The Model RBVS is designed to monitor the fully open position of a ball valve installed in a sprinkler system. The unit will fit on most ball valves installed on back-flow-preventers and alarm trim lines of dry, alarm, and deluge sprinkler valves. The switch operates if the ball valve handle is moved from the open position. However, the switch does not track the position of the handle or ball. When the ball valve handle is in the open position, a spring-loaded switch button will contact the valve handle. When the handle is moved from the open position, this switch button extends to the tripped position, and the RBVS contacts change state, thereby opening or closing a circuit. A cover tamper switch is available and is activated by the removal of the RBVS housing cover. If an attempt is made to remove the RBVS by the removal of the mounting brackets, the unit will be set into the tripped mode by this action.

The RBVS can be mounted to the hex portion of the ball valve or back-flow-preventer or to the adjoining pipe via two clamps. The RBVS is shipped with two sets of mounting clamps to accommodate various pipe and valve sizes, refer to Table 1. An "L" shaped and offset bracket for mounting the switch enclosure and an extension bracket add to the mounting flexibility of the RBVS. See "Typical Mounting Diagram" and "Installation and Operation" on following page.

Testing

The RBVS and its associated protective monitoring system should be tested in accordance with applicable NFPA codes and standards and/or the authority having jurisdiction (manufacturer recommends quarterly or more frequently).

Fig.1 Internal Components

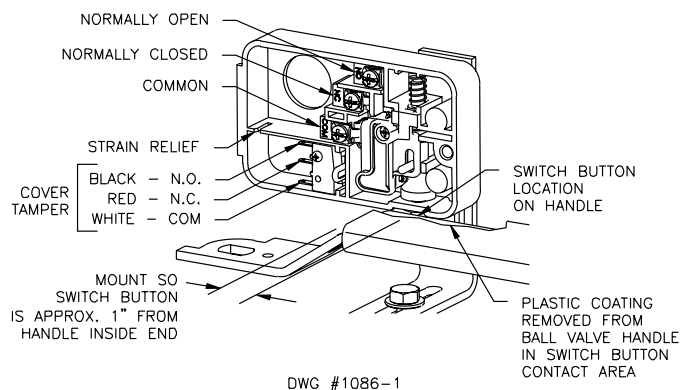

Installation On Lever Handle (See Fig. 2)

1. Select clamps and clamping bolts based upon pipe/valve size, see Table 1.
2. Insert rubber clamp grippers into clamps, see Fig. 2.
3. Place one clamp on top of pipe/ball valve near the valve handle and insert clamping bolts through it.
4. Place other clamp over clamping bolts from beneath the installation and thread hex nuts onto the clamping bolts, but do not fully tighten, (be sure hex nuts seat properly in clamp hex recesses). (NOTE: Some installations may require one of the mounting bolts to be inserted from the bottom of the brackets and then trimmed to allow the extension bracket to clear. See Fig. 4)
5. Attach extension bracket (if necessary to use for positioning) to top clamp using ¼-20 X ¾" Hex bolt and washer, but do not fully tighten.
6. Attach "L" bracket (RBVS switch enclosure is loosely attached to "L" bracket) to extension bracket using ¼-20 X ¾" Hex bolt and washer, but do not fully tighten.
7. Be sure ball valve is in the fully open position.
8. Slide loosely assembled RBVS switch enclosure to a position that permits the switch button to contact the valve handle approximately 1" from its inside end. See Fig. 1 for approximate location. Cut and remove the plastic coating from the ball valve handle to allow the RBVS switch button to contact (and be activated by) the metal of the handle.
9. Tighten clamping screws alternately to an eventual 30 in-lbs. (minimum) of torque.
10. Maintain position of switch enclosure over valve handle and secure bolt that holds the extension bracket to the clamping assembly. It may be necessary to close valve to access this bolt.
11. Position "L" bracket so that it contacts the back edge of the valve handle, and secure its bolt. It may be necessary to close valve to access this bolt.
12. With the actuator fully retracted, position RBVS switch enclosure to contact the valve handle squarely, see Fig. 1.
13. With RBVS switch enclosure held squarely in contact with valve handle, securely tighten the two tamper resistant screws on the backside of the enclosure.
14. Close and open the valve to verify operation. The actuator should easily retract when the valve handle is in the open position.
15. Fully open the valve.
16. Remove the cover and wire main switch and tamper switch if applicable. Carefully route tamper switch wires through strain relief channel in switch enclosure. Fully seat the wires into the bottom of the channel. See Fig. 1.
17. Replace RBVS switch enclosure cover and securely tighten cover screw.

Fig. 2 Typical Mounting Diagram

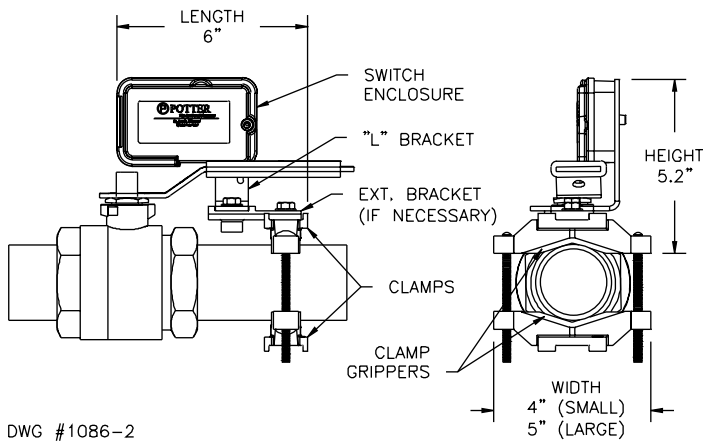

DWG #1086-2

Table 1 Clamp Sizing

Pipe Valve/Size	Clamp	Clamping Bolts
1/2" to 3/4" (12,5 to 19mm)	Small	10-32 x 2 1/2"
1" to 2" (25 to 50mm)	Large	1/4-20 x 4"

Switch Terminal Connections, Clamping Plate Terminal

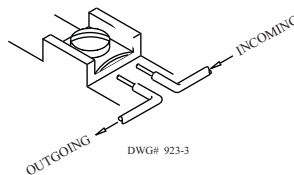

CAUTION

An uninsulated section of single conductor should not be looped around the terminal and serve as two separate connections. The wire must be severed, thereby providing supervision of the connection in the event that the wire becomes dislodged from under the terminal.

Typical Electrical Connections

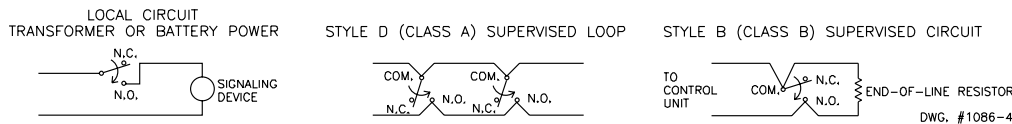

Tamper Switch Connections

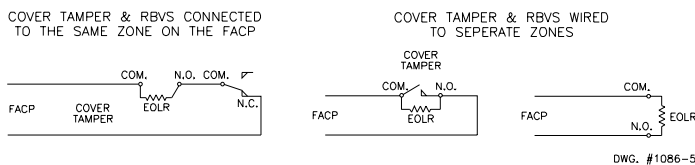

Installation on Tee Handle (See Fig. 3)

1. Select clamps and clamping bolts based upon pipe/valve size, see Table 1.
2. Insert rubber clamp grippers into clamps, See Fig. 3.
3. Place one clamp on top of pipe/ball valve near the valve handle and insert clamping bolts through it.
4. Place other clamp over clamping bolts from beneath the installation and thread hex nuts onto the clamping bolts, but do not fully tighten, (be sure hex nuts seat properly in clamp hex recesses).
5. Loosely attach "L" bracket to the "offset" bracket and "offset" bracket to the RBVS housing.
6. Be sure ball valve is in the fully open position.
7. Slide loosely assembled RBVS switch enclosure to a position that permits the switch button to contact the valve handle approximately 1/2" from the end of the handle. Cut and remove the plastic coating from the ball valve handle to allow the RBVS switch button to contact (and be activated by) the metal of the handle.
8. Tighten clamping screws alternately and 1/4-20 X 3/4" bolt to 30 in-lbs. (minimum) of torque.
9. With the valve handle fully open, slide the RBVS housing down until the switch operates plus 1/8 inch. Tighten the screws holding the RBVS to the "offset" bracket.
10. Remove the RBVS switch enclosure cover.
11. Close and open the valve to verify operation. The actuator should easily retract up when the valve handle is in the open position.
12. Fully open the valve.
13. Wire main switch and tamper switch (if applicable). Carefully route tamper switch wires through strain relief channel in switch enclosure. Fully seat the wires into the bottom of the channel. See Fig. 1.
14. Replace RBVS switch enclosure cover and securely tighten cover screw.

Fig. 3

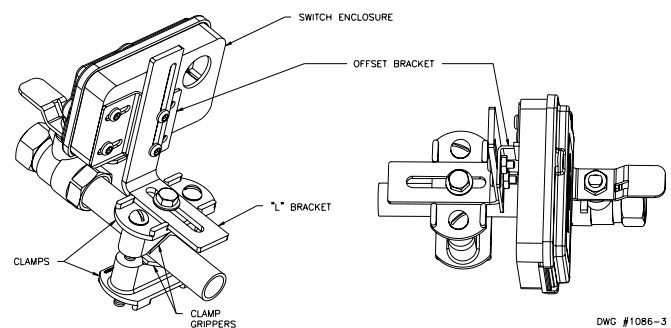

Fig. 4

