



## Model 5895XL Intelligent Power Module



### The intelligent way to distribute power throughout your installation.

With 6.0 amps of output power, six programmable Flexput™ I/O circuits, and two Form C relay contacts, the Model 5895XL Intelligent Power Module allows you to greatly enhance the capabilities of an IntelliKnight system, distributing power where needed throughout a facility.

5895XL modules connect via the RS-485 system bus. Up to eight 5895XL modules can be used per IntelliKnight system. Each 5895XL has its own optically isolated RS-485 bus to which other modules, such as 5860 remote annunciators and 5824 printer interface modules, can be connected. You can also connect 5815XL SLC expansion modules, adding flexibility and wiring distance. Each 5895XL supports its own backup batteries and monitors the AC power.

#### Description

5895XL adds 6.0 amps of power, six Flexput I/O circuits, and two Form C relay circuits to an IntelliKnight installation. The 5895XL is optically isolated providing ground loop isolation and transient protection. The 5895XL conditions the RS-485 system bus allowing up to an additional 6,000 feet of wiring.

#### Operation

The green LED on the 5895XL board indicates communication with the IntelliKnight FACP.

The Flexput circuits can be notification appliance circuits, continuous power, resettable power, door holder power or initiation circuits that can support both 2- and 4-wire smoke detectors. All Flexput circuits and relay outputs are individually mappable from the IntelliKnight 5820XL FACP.

#### Features

- 6.0A output power
- Flexput I/O circuits, 3A each, programmable as notification circuits, auxiliary power circuits, or initiation circuits
- Supports Class A configuration for SBUS & Flexput circuits
- Ground loop isolation
- 2 Form C programmable relays rated at 2.5A at 24 VDC
- Transient protection
- SBUS repeater conditions the RS-485 signal

- Up to 6,000 feet wiring distance from 5895XL (same distance as main FACP)
- Battery charging capacity 35 Ah
- Large cabinet can house two 18 Ah batteries or RBB accessory cabinet can house battery sizes larger than 18 Ah
- Room in FACP cabinet to mount two 5815XL SLC expanders
- Built-in synchronization for appliances from AMSECO®, Gentex®, Faraday, System Sensor®, and Wheelock®

#### Electrical Specifications

Primary AC:  
120 VRMS @ 60 Hz, 2.5A  
240 VRMS @ 60 Hz, 1.4A  
Total Accessory Load:  
6A @ 24 VDC  
Current:  
Standby: 40 mA  
Alarm: 160 mA  
I/O Circuit Power:  
3A per circuit (6A total per system)

#### Mechanical Specifications

Flush or surface mount  
Dimensions:  
14-1/2"W x 24-3/4"H x 3-7/8"D  
(36.8 W x 62.9 H x 9.8 D cm )  
Overall Dimensions:  
16-1/8"W x 26-3/8"H x 4-1/8"D  
(40.6 W x 67 H x 11.8 D cm)  
Color: Red

#### Environmental

Operating Temperature:  
32°F – 120°F (0° – 49°C)  
Humidity: 10% – 93%  
non-condensing



Model 5895XL

#### Approvals

- NFPA 13, NFPA 15, NFPA 16, NFPA 70, NFPA 72 and NFPA 101
- UL 864
- CSFM
- MEA 429-92-E, Vol. IX
- FM approved



# Model 5895XL Intelligent Power Module



## Engineering Specifications

The contractor shall supply a power module compatible with the IntelliKnight Model 5820XL FACP. The power module must have 6.0 amps of output power, Flexput I/O circuits rated 3.0 amps each, and two Form C relay contacts rated at 2.5 amps at 24 VDC. The power module shall connect to the main FACP via an RS-485 system bus (SBUS). The power module shall contain an additional RS-485 bus that is completely compatible with all IntelliKnight add-on modules, including 5815XL SLC expanders, 5860 remote annunciators, 5824 serial/parallel printer interface modules.

The power module RS-485 bus shall be optically isolated providing ground loop isolation and transient protection. The unit shall be an SBUS repeater that conditions the signal driving up to 6,000 feet of additional wiring.

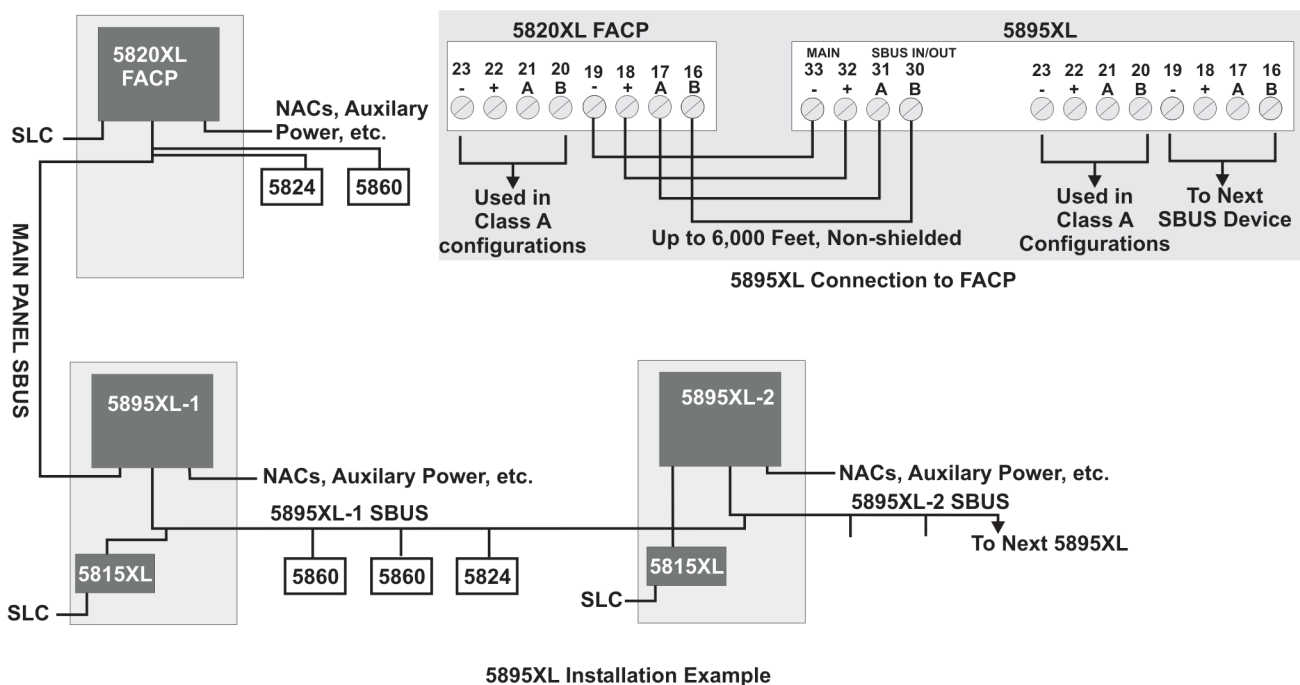

This document is not intended to be used for installation purposes. We try to keep our product information up-to-date and accurate. We cannot cover all specific applications or anticipate all requirements. All specifications are subject to change without notice. For more information, contact Silent Knight 7550 Meridian Circle Suite 100, Maple Grove, Mn 55369-4927. Phone: (800) 328-0103, Fax: (763) 493-6475.

IntelliKnight is a Registered Trademark of Silent Knight  
Flexput is a Trademark of Silent Knight

**MADE IN AMERICA**

FORM# 350212 Rev. C, 02/06

Copyright © 2006 Silent Knight