



Model SD505-DUCT Duct Smoke Detector



Detect smoke in air handling systems and air handling equipment with Silent Knight's addressable duct smoke detector

The SD505-DUCT addressable duct smoke detector including the SD505-APS Analog Photoelectric Smoke Sensor is used for detecting smoke and products of combustion present in air moving through an HVAC air handling system. When smoke is detected in a duct, the unit communicates the condition to the IntelliKnight control panel. The panel, in turn, depending on programming and wiring, turns off fans, blowers, and other devices. Now there's even more power and flexibility available to the IntelliKnight family of products!

Model SD505-DUCT Duct Smoke Detector

The Model SD505 DUCT Duct Smoke Detector is a heavy duty detector housing with the SD505-APS Analog Photoelectric Smoke Sensor pre-installed. It provides early detection of smoke and products of combustion present in air moving through HVAC ducts in Commercial and Industrial applications.

The SD505-DUCT is in a heavy duty gray steel back box with a clear cover. It installs quickly and easily.

Operation

Air sampling is accomplished by two tubes which protrude into the duct. An exhaust tube of one standard length (7.5") is provided with the detector housing. Intake sampling tubes (ordered separately) are supplied in three standard lengths. Duct mounting is accomplished through a template and 4 sheet metal screws (provided).



SD505-DUCT

Features

- Two-wire connection to SLC
- LED alarm indication and communication on sensor head
- Detects and limits the spread of smoke
- Rugged steel backbox with clear plastic cover
- Installation template included
- Large terminal connection screws
- 3 standard tube lengths
- UL 268A listed, complies with NFPA 72 and 101

Specifications

Included Parts: Metal housing with 7.5" exhaust tube
SD505-APS analog Photoelectric sensor
Installation template
4 mounting screws

| | |
|-------------------|--|
| Accessory models: | (parts not included with SD505-DUCT) |
| SD505-T2 | Sampling tube for 6" to 2.5' duct width |
| SD505-T5 | Sampling tube for 2.5' to 5.0' duct width |
| SD505-T10 | Sampling tube for 5.0' to 10.0' duct width |

Current: .55 mA
(alarm and standby)

Air Velocity: 300 to 4000 fpm

Ambient Temperature: 32°F to 120°F
(0°C to 49°C)

Humidity: 10 to 85% RH

Dimensions: 91/8" H x 7.25" W x 2.25" D

Color: Gray backbox with clear cover



Model SD505-DUCT Duct Smoke Detector



Engineering Specifications

The air duct smoke detector shall be Silent Knight Model SD505-DUCT. The housing shall contain a Analog Photoelectric Smoke Sensor , Silent Knight model SD505-APS. The detector head must perform an automatic sensitivity check every 3 hours.

The duct detector housing shall be of metal construction. Complete mechanical installation must be able to be performed without removal of the detector cover. Terminal connections shall be screw type using a minimum of #6 screw.

SD505-DUCT Dimensions

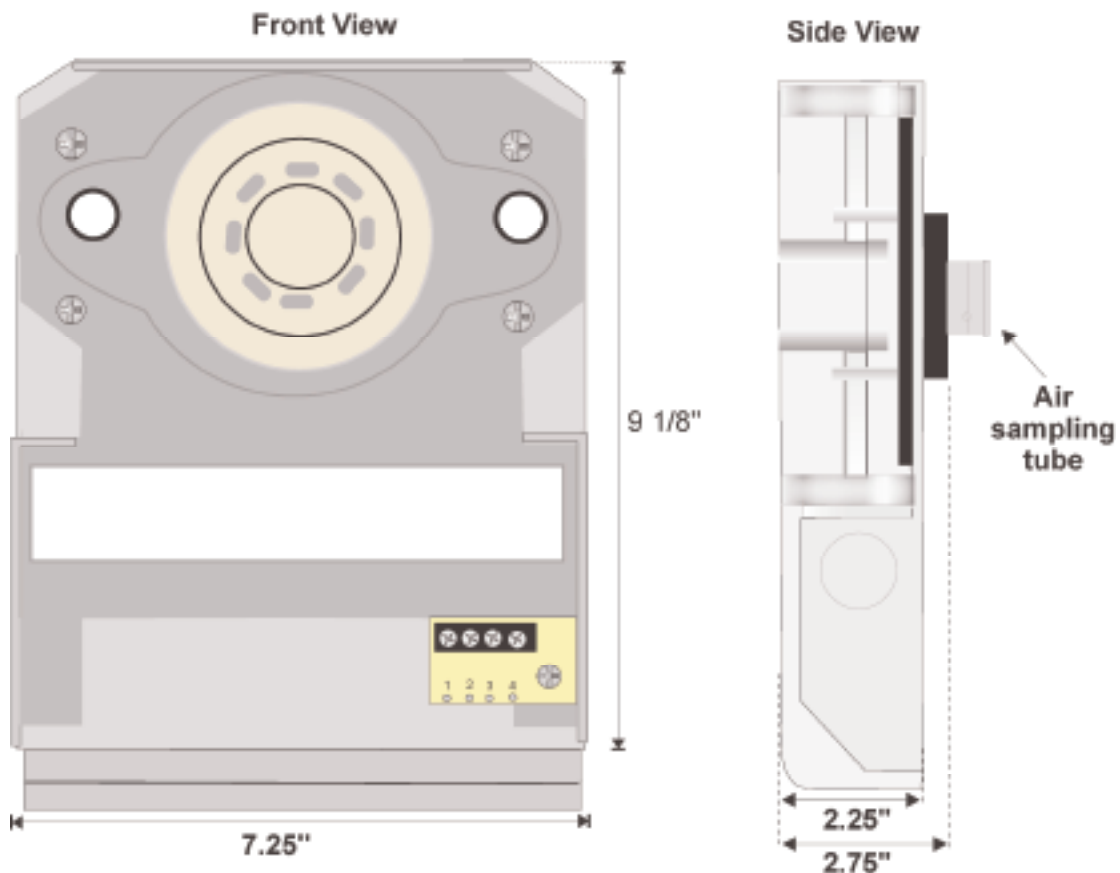

This document is not intended to be used for installation purposes. We try to keep our product information up-to-date and accurate. We cannot cover all specific applications or anticipate all requirements. All specifications are subject to change without notice. For more information, contact Silent Knight 7550 Meridian Circle Suite 100, Maple Grove, Mn 55369-4927. Phone: (800) 328-0103, Fax: (763) 493-6475. www.silentknight.com

MADE IN AMERICA

FORM# 350705 10/07

© 2007 Honeywell International Inc.