

# STI MINI STOPPER®

## This Series of Protective Covers are Used to Protect a Wide Range of Fire Pull Stations, Digital Keypads, Push Buttons, Controls and Other Devices

This unique device has been helping stop false fire alarms around the world for decades, without restricting legitimate operation of your pull station. Other versions of this same cover are used to protect devices such as access controls, digital keypads, smaller manual pull stations, shutdown switches in computer rooms or workshops and many more. These versatile covers offer excellent protection against physical damage (both accidental and intentional), dust and grime as well as severe environments inside and out. The Mini Stopper (STI-6500) consists of a clear, tough polycarbonate cover and frame that fits over the unit you wish to protect. When additional security is needed, the Mini Stopper® II (STI-6600) unit with the 9 VDC horn is recommended. When the cover is lifted to gain access to the protected unit, its battery powered alarm emits a piercing 105 dB at a one foot distance. Immediate attention is drawn to the area and a prankster will either run or be caught. With gaskets, Mini Weather Stopper® (STI-6525) can dramatically extend the life of equipment mounted in saltwater areas or areas requiring frequent hosing down.

### Cover Has a Lifetime Warranty

Molded from super tough polycarbonate material, Mini Stopper polycarbonate cover is backed by a lifetime guarantee against breakage and damage in normal use with one year on electronic components.



STI-6600



STI-6500  
(Cover only)



## Features

- Protects against vandalism, accidental damage, dust and grime as well as severe environments inside and outside.
- Mini Weather Stopper dramatically extends the lifespan of devices in saltwater areas.
- Standard red units have "In Case of Fire..." label unless specified no label or custom label (charge for custom label).
- Cover is molded from thick, super tough polycarbonate material.
- Lifetime guarantee against breakage of polycarbonate cover with normal use (one year on electronic components).
- Models available with or without 105 dB horn.
- Perfect for protecting shutdown switches in computer rooms and workshops as well as other push buttons.
- STI-6500 and STI-6505 can be used over volume and lighting controls.
- Available with red, green, blue or yellow horn housing shell with custom labeling.
- Matching spacer available for surface mount units.
- Polycarbonate rated -40°F to 120°F (-40°C to 49°C).
- UL Listed to U.S. and Canadian safety standards for standard and custom labeling.
- Weather resistant covers available.
- Fast and easy installation.



## Safety Technology International, Inc.

2306 Airport Road • Waterford, Michigan 48327-1209

Phone: 248-673-9898 • Fax: 248-673-1246 • Toll Free: 800-888-4784 • E-mail: [info@sti-usa.com](mailto:info@sti-usa.com) • Web: [www.sti-usa.com](http://www.sti-usa.com)

Europe Branch Office • Unit 49G Pipers Road • Park Farm Industrial Estate • Redditch • Worcestershire • B98 0HU • England

Tel: 44 (0) 1527 520 999 • Fax: 44 (0) 1527 501 999 • Freephone: 0800 085 1678 (UK only) • E-mail: [info@sti-europe.com](mailto:info@sti-europe.com) • Web: [www.sti-europe.com](http://www.sti-europe.com)

# STI MINI STOPPER®

## Dimensions and Technical Information

### Models Available

- STI-6500** Mini Stopper Without Horn Flush Mount
- STI-6505** Mini Stopper Without Horn with Spacer
- STI-6510** Mini Stopper Without Horn Flush Mount with Lock
- ★ **STI-6525** Mini Weather Stopper® (Indoor/Outdoor Rated) with gaskets - Flush Mount
- ★ **STI-6535** Mini Weather Stopper (Indoor/Outdoor Rated) with gaskets - with Spacer
- STI-6540** Mini Stopper® II Without Horn Flush Mount
- STI-6545** Mini Stopper II Without Horn with Spacer
- STI-6600** Mini Stopper II With Horn Flush Mount
- STI-6605** Mini Stopper II With Horn and Spacer
- STI-6610** Mini Stopper II With Horn Flush Mount with Lock
- STI-6515** Mini Stopper® Seal tamper resistant accessory for use with Mini Stopper (see separate spec)
- STI-6531** Conduit Spacer for surface mounting
- STI-6532** Clear 1.25 in. spacer
- STI-6602** Replacement horn for cover with alarm
- SUB-317** Weather gasket kit for flush or surface covers (included in weather models)

### Important Notice

Mini Stopper II is intended to be used in areas where the incidence of false fire alarms from manual pull stations is high or has proven to be a serious problem. Any disadvantage of this device is more than balanced when one considers the consequences of false fire alarms, especially if fire service personnel and equipment are responding to a false fire alarm when they are needed for a real fire somewhere else. Add to this the disruption to the facility when false alarms occur. If you have, or may have, a problem with false fire alarms or physical/weather damage to your fire alarm activation devices, the Mini Stopper II could prove invaluable.

- ★ **NOTE:** To maintain UL Listing for outdoor applications, UL requires the manual pull station that the cover is mounted over be UL Listed for outdoor use.
- End user must verify the alarm and battery every six months and replace battery annually or as required.

### Approvals\*

It has been tested and approved or listed by:

- Underwriter Laboratories No. S2466.
- For fire alarm applications, UL38 requires outdoor listed stations for outdoor use.
- Canada Underwriter Laboratories No. S2466
- MEA Approved #49-00-E (STI-6500 and STI-6505)
- CSFM Approved (STI-6500 only) for use over STI Fire Stopper® Station (SS2000F)
- ADA Compliant
- NEMA 3R (STI-6525 and STI-6535) only when mounted on a smooth surface or when mounted with the STI-6581.

\***Note:** No approvals on STI-6510, STI-6515 and STI-6610.

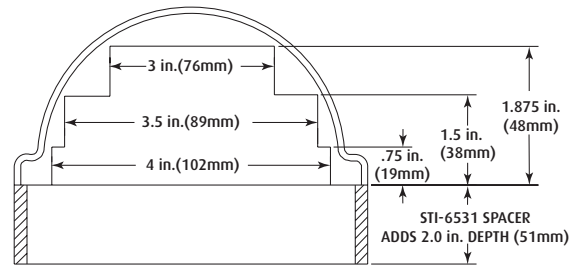

DEPTH CHART FOR MINI STOPPER AND CONDUIT SPACER

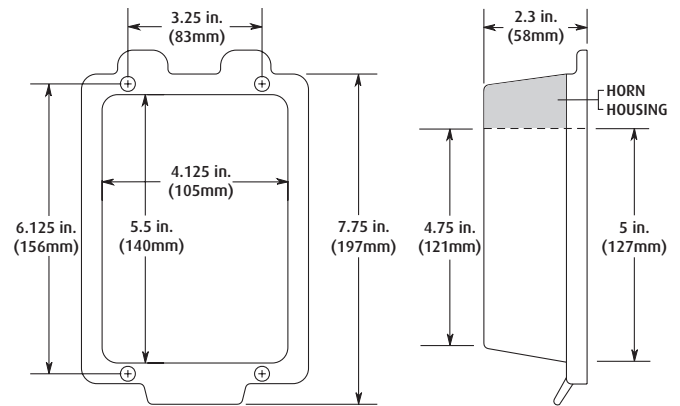

FRONT VIEW

SIDE VIEW

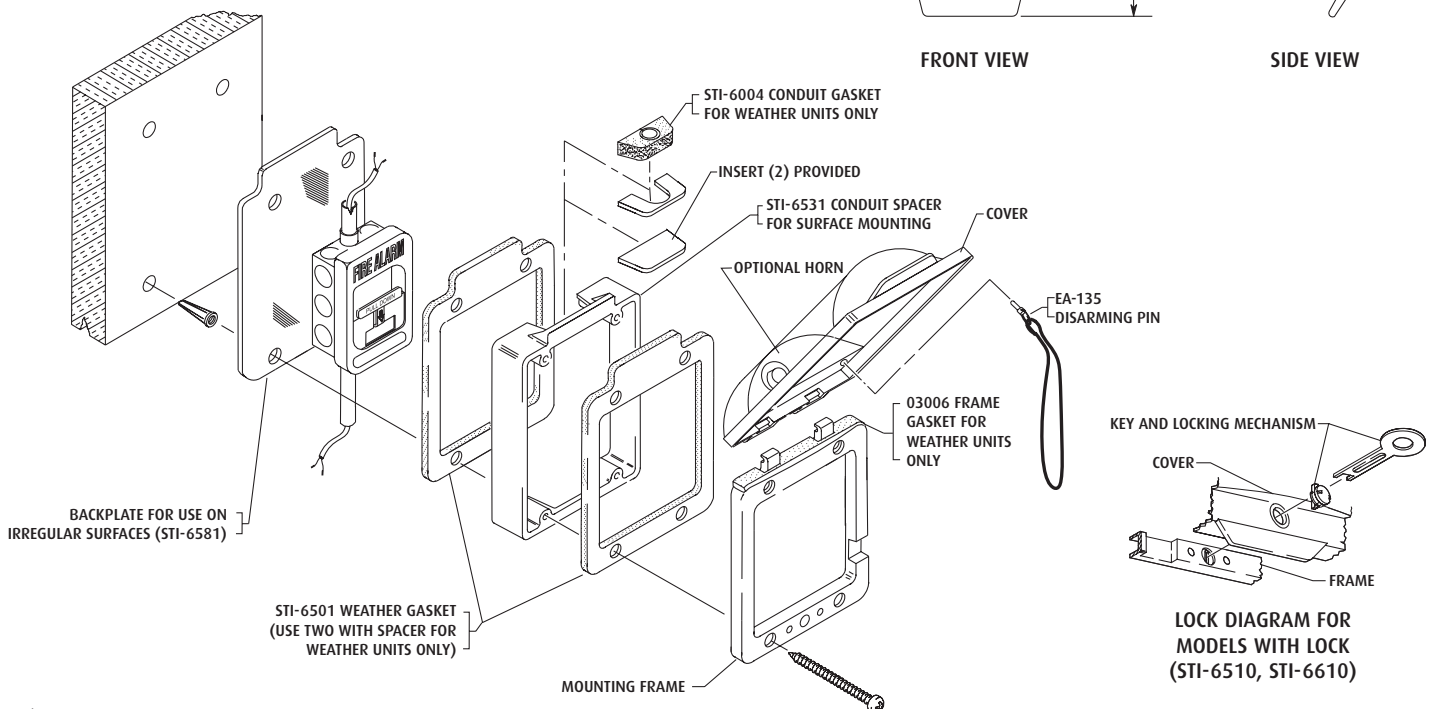

LOCK DIAGRAM FOR MODELS WITH LOCK (STI-6510, STI-6610)